

VEHICLES HEATERS

**B 2 L** (petrol)  
**D 2 L** (diesel)

J. EBERSPÄCHER  
EBERSPÄCHERSTRASSE 24  
D-7300 ESSLINGEN  
TEL. (07 11) 31 09-1  
TELEX 7 256 426

Air heaters independent of engine for universal installation

<b>B 2 L</b>	Cat. No.	<b>D 2 L</b>	Cat. No.
Basic heater with standard equipment	12 V 20 1667 05 00 00	Basic heater with standard equipment	12 V 25 1625 05 00 00
Universal installation kit	20 1667 80 00 00	Universal installation kit	20 1667 80 00 00



**Specifications**

Heating medium	Air
Heating air flow without counterpressure <sup>1)</sup>	80 kg/h $\pm$ 10%
Heating capacity <sup>1)</sup>	2300 W $\pm$ 10%
Regulation of heating capacity	with room thermostat
Fuel <sup>2)</sup>	B 2 L: petrol (commercial grade) D 2 L: diesel (commercial grade)
Fuel consumption <sup>1)</sup>	B 2 L: 0.32 l/h $\pm$ 10% D 2 L: 0.27 l/h $\pm$ 10%
Rated voltage	12 V
Operating range	
Minimum voltage <sup>3)</sup>	10 V
Maximum voltage <sup>4)</sup>	14 V
Electrical power consumption <sup>1)</sup>	B 2 L at start 150 W $\pm$ 10% in operation 15 W $\pm$ 10% D 2 L at start 240 W $\pm$ 10% in operation 15 W $\pm$ 10%

Ventilation operation	possible
Radio interference suppression	Remote, additional suppression measures possible
Weight	approx. 14 kg

- <sup>1)</sup> at rated voltage
- <sup>2)</sup> see also "Fuel at low temperatures", page
- <sup>3)</sup> an undervoltage safety device built into the control unit switches off the heater at approx. 10.5 V.
- <sup>4)</sup> an overvoltage safety device built into the control unit switches off the heater at approx. 15 V.

**Contents:**

	Page
Scope of delivery/Cat. No. ....	2, 3
Official regulations .....	4
Installation instructions .....	4
Typical installations/Installation position .....	4
Running the heating air .....	5
Fitting the heater .....	6
Permissible installation positions/Fastening the heaters ...	6
Principal dimensions .....	6
Running the combustion air/exhaust .....	7
Fuel supply .....	8, 9
Room thermostat, electrics/Wiring diagrams .....	10-12
Description of operation .....	13, 14
Elimination of faults .....	15

Item	Qty.	Designation/Cat. No.
-	1	Cable to room thermostat, 5000 mm long
57	1	Reduction piece
58	1	Gasket sheet
59	1	Hose socket
60	1	Connection piece
61	1	Reduction piece
62	lin.m.	Flexible hose, dia. 90
63	lin.m.	Flexible hose, dia. 100
64	1	Heating timer, 12 V with fasteners

**Scope of delivery** (see page 3 for illustration)

Item	Qty.	Designation/Cat. No.
------	------	----------------------

**B 2 L**

1-10	1	Basic heater with standard equipment 12 V
------	---	--

**D 2 L**

1-10	1	Basic heater with standard equipment 12 V
------	---	--

Standard equipment includes:

1	1	Basic heater (not available alone) B 2 L
		D 2 L
2	1	Control unit
3	1	Fuel metering pump
4	1	Mounting, compl.
5.1-5.4	1	Connectors
6	1	Intake silencer
7	1	Copper earthing strap (B 2 L only)
8	1	Holder
9	1	Room thermostat, 12 V
10	1	Screen

to be ordered additionally for B 2 L and D 2 L:

11-48	1	Universal installation kit
-------	---	----------------------------

65	1	Heating timer, 12 V with fasteners
----	---	------------------------------------



See Additional Equipment Catalog for other accessories.

**Additional equipment**

Item	Qty.	Designation/Cat. No.
49	1	Connection piece, compl.
50	1	Outlet, 90/100 rotatable
51	1	Air outlet
52	1	Air distributor box, compl.
53	1	Outlet
54	1	Y piece
55	1	Protective grid, painted
56	1	Cable to room thermostat, 2500 mm long



## Official regulations

For vehicles registered in West Germany (subject to the road traffic regulations StVZO), the heaters are approved by the Federal Motor Vehicle Office and receive an official test symbol (indicated on the name plate).

Please note:

The year of first operation is a requirement of German admission not representing a model number. If the heater is installed in special-purpose vehicles (e.g. vehicles transporting dangerous cargoes), the regulations applicable to such vehicles must be observed.

**Important:**

**The heater must not be operated in garages. It must also never be switched on while the tank is being filled.**

## Installation Instructions

The suggestions put forward in these installation instructions are only examples. Possibilities other than those illustrated (e.g. with regard to the choice of installation location, method of running air) are also permissible, provided they meet the

requirements of the West German road traffic regulations (StVZO), and if necessary after consultation with the manufacturer.

## Typical installation/Installation location

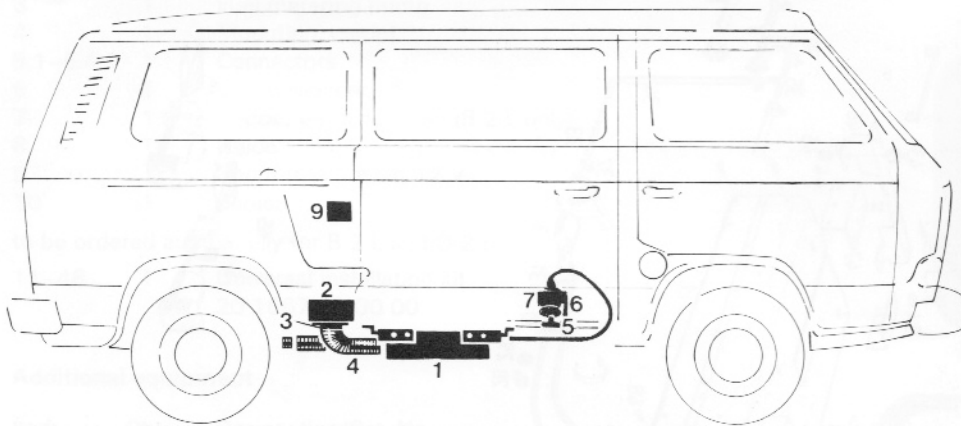

Item	Designation
1	Heater
2	Air distributor box
3	Connection piece
4	Flexible pipe
5	Fuel branch
6	Mounting for fuel metering pump
7	Fuel metering pump
8	Exhaust pipe
9	Room thermostat

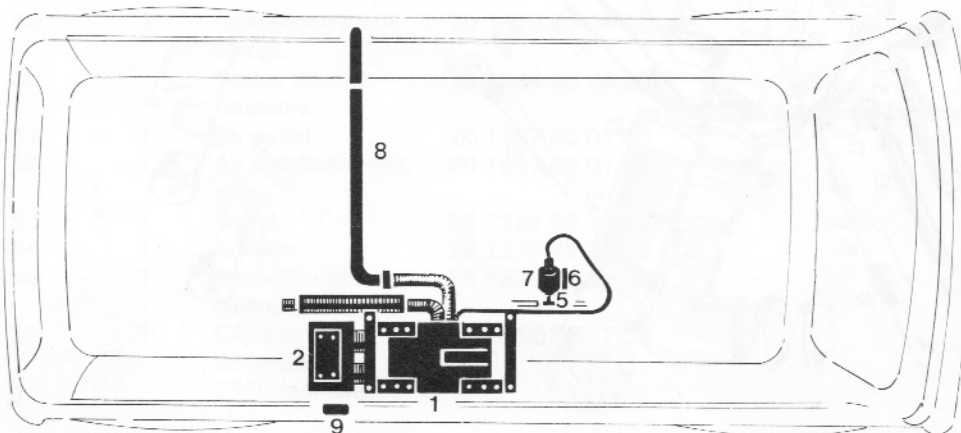

33/137

## Circulated air intake line/heating air outlet line

The air is always sucked in from the area to be heated (circulated air).  
Usual parts for intake and outlet sides:

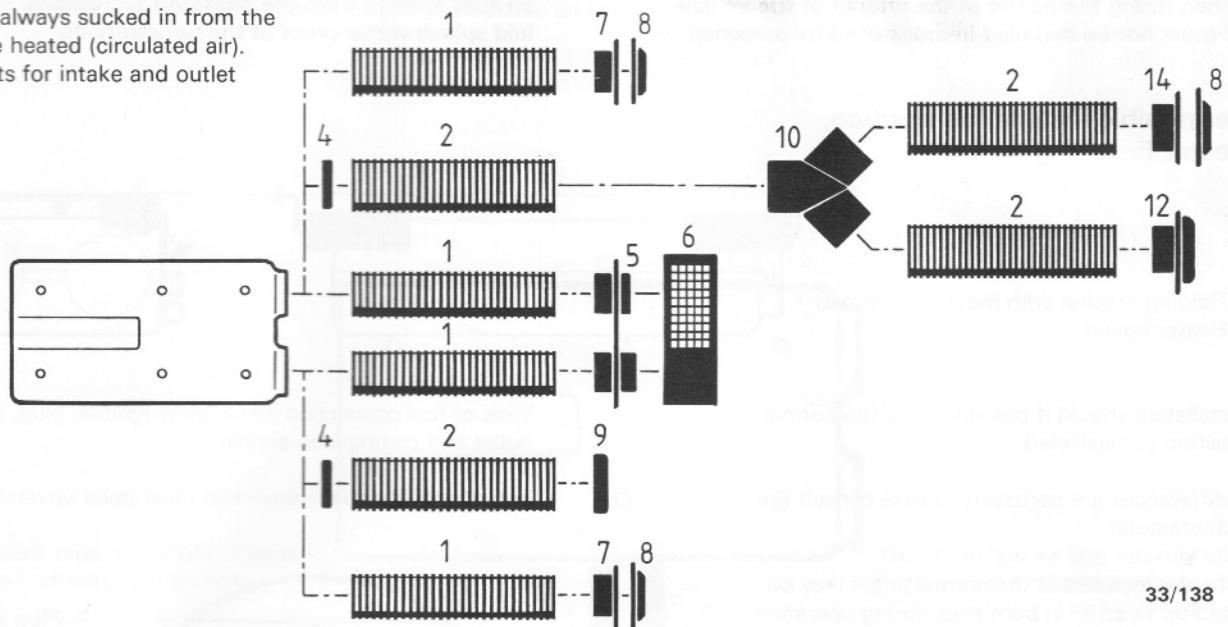

33/138

Item	Designation	Component rating		Cat. No.
		1-duct*	2-duct*	
1	Flex. hose, dia. 90	2.15/m	0.46/m	360 00 118
2	Flex. hose, dia. 100	1.0/m	0.3/m	360 00 123
4	Reduction piece, 90/100	-	-	20 1462 89 00 01
5	Connection piece	-	-	20 1629 80 06 00
6	Air distributor box	2.5	-	20 1607 89 01 00
7	Connection socket dia. 90	0.3	0.15	20 1297 00 00 01
8	Air exhauster	1.5	0.38	20 1297 00 01 00
9	Protective grid dia. 100	1	-	25 1226 89 44 00

Item	Designation	Component rating		Cat. No.
		1-duct*	2-duct*	
10	Y piece, 100/100/100	0	-	25 1226 89 34 00
12	Outlet, rotatable dia. 90/100	2.3	0.46	20 1609 80 09 00
14	Connection socket dia. 100	0.15	0	25 1226 89 00 11
16	Flex. pipe bend, 90°, dia. 90	2.46	0.46	-

The sum of the component ratings may not exceed the heater rating.

\*1-duct means: one combustion air duct leads to or from the heater.  
The component ratings given under "1-duct" apply.

\*2-duct means: behind the heater, the combustion air branches into 2 ducts. Up to this branch, the ratings under "1-duct" apply, after it those under "2-duct".

## Example of determination of rating

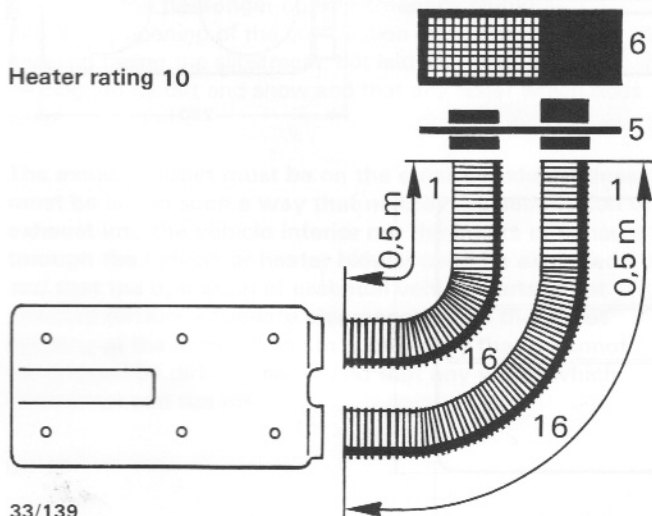

33/139

Item	Designation	Component rating
1	1 m flex. hose, dia 90	2.15
5	Connection piece	-
6	Air distributor box	2.50
16	2 x 90° pipe bends	4.92
Sum of component ratings		9.57

The total of component ratings, 9.57, does not exceed the heater rating of 10; installation is permissible.

The inlet and outlet for the heating air in the vehicle must be arranged so that the hot air flowing out cannot be sucked in again directly, that exhaust from the vehicle engine and the heater cannot be sucked in, and that the hot air cannot be contaminated.

## Fitting the heater

When fitting the heater in the interior of the vehicle (it must not be installed in areas used by persons),

all lines leading from the heater to the outside must be laid splash-water-proof at the penetrations.

## Permissible installation position, heater fastening

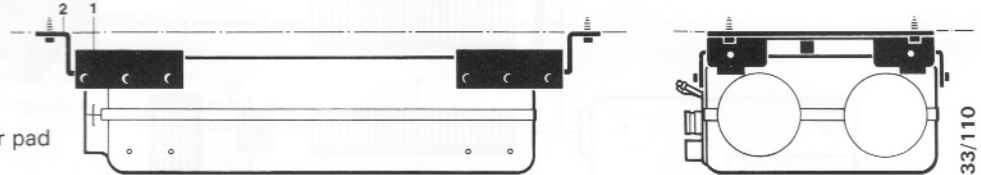

- 1 Holding bracket with metal-rubber pad
- 2 Heater holder

Installation should if possible be in the normal position as illustrated.

View of fuel connection piece, glow-ignition plug, exhaust outlet and combustion air inlet.

If differences are necessary, please consult the manufacturer.

**Important:** The fuel connection must point upwards.

A heater installed at the normal angle may be tilted up to  $\pm 15^\circ$  in both axes during operation, due to the inclination of the vehicle during motion.

The factory plate must be clearly visible when the heater is installed. If necessary, a second plate (duplicate) may be affixed, with the same information as the original, to a place on the heater clearly visible after installation, or to a cover placed in front of the heater. A second plate is not necessary if the original is visible after removal of a cover without the aid of tools.

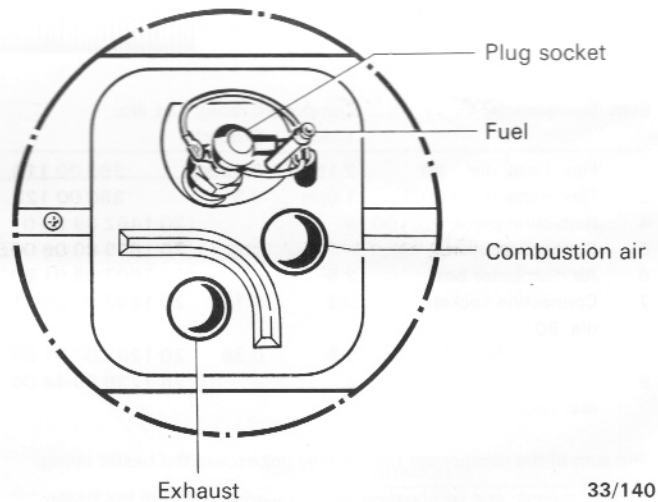

## Principal dimensions

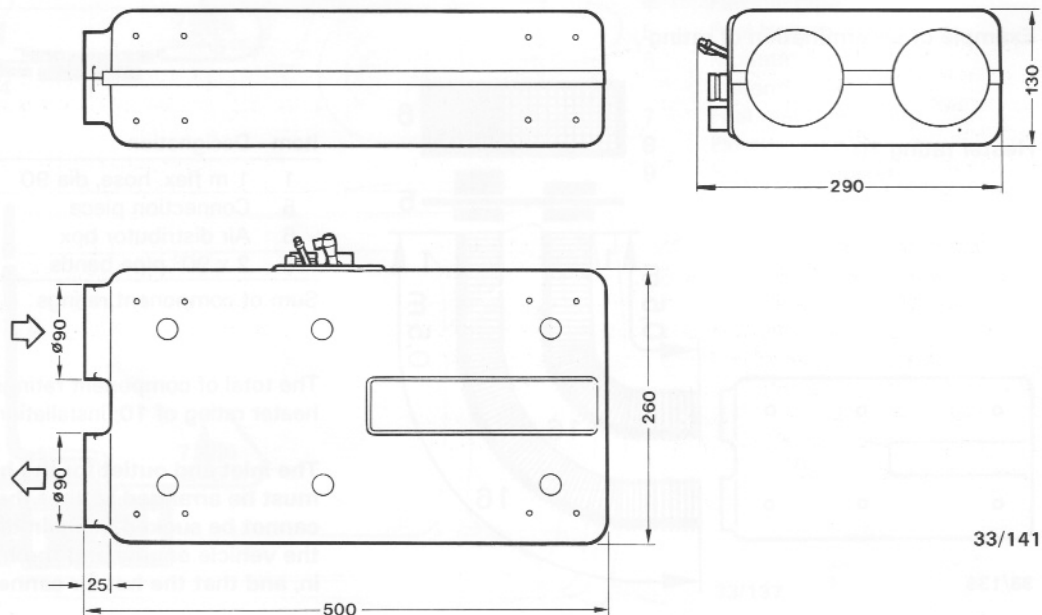

## Running the combustion air/exhaust

Permissible lengths and diameters of exhaust and combustion air lines.

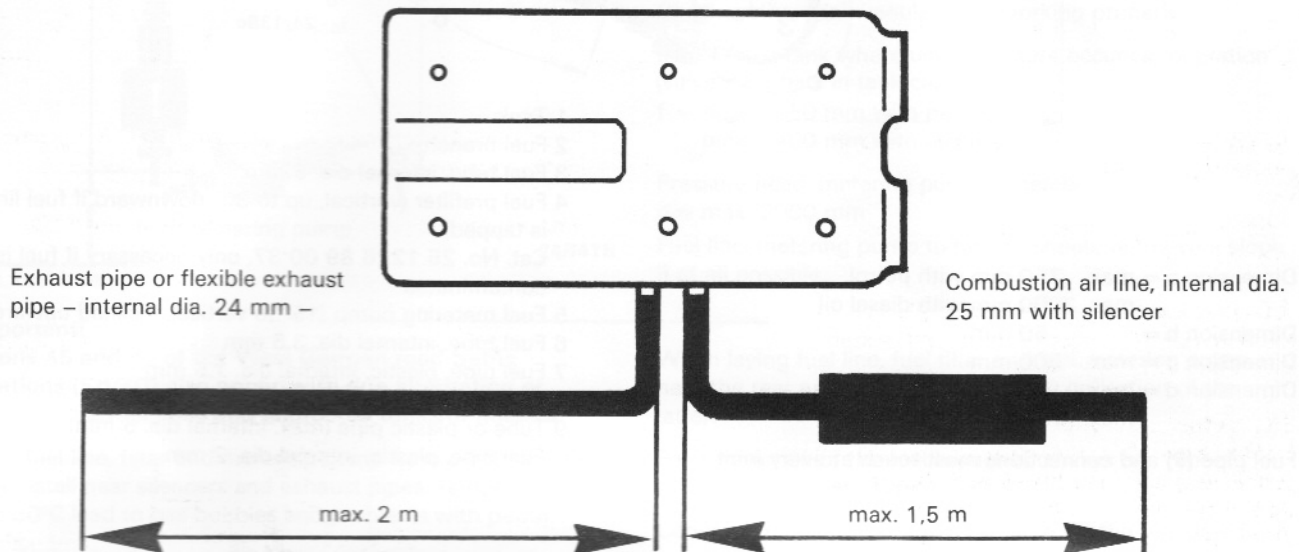

33/142

The combustion air must be sucked in from the outside (not from the passenger compartment or trunk).

The intake opening of the combustion air line must not be installed facing the slipstream, but laid such that it cannot be clogged by dirt and snow and that any water which does enter can run off.

The exhaust outlet must be on the outside. Exhaust lines must be laid in such a way that neither the penetration of exhaust into the vehicle interior nor the intake of exhaust through the vehicle or heater blower need be expected<sup>1)</sup> and that the operation of essential vehicle parts is not affected (ensure adequate clearance). Place the outlet opening of the exhaust line in such a way that it cannot be clogged by dirt and snow and that any water which does enter can run off.

Exhaust lines must not project beyond the sides of the vehicle. Lay the exhaust line either with a slight slope or with drain holes of 5 mm diameter at the lowest points.

It must not be possible to suck in exhaust through the combustion air blower.

<sup>1)</sup> This requirement can be considered met if the outlet opening of the exhaust line is located at the usual places in motor vehicles, e.g. in engine compartment, wheel case, or on the vehicle underside.

## Fuel supply

### 1. Fuel intake from fuel line to engine (usually passenger cars):

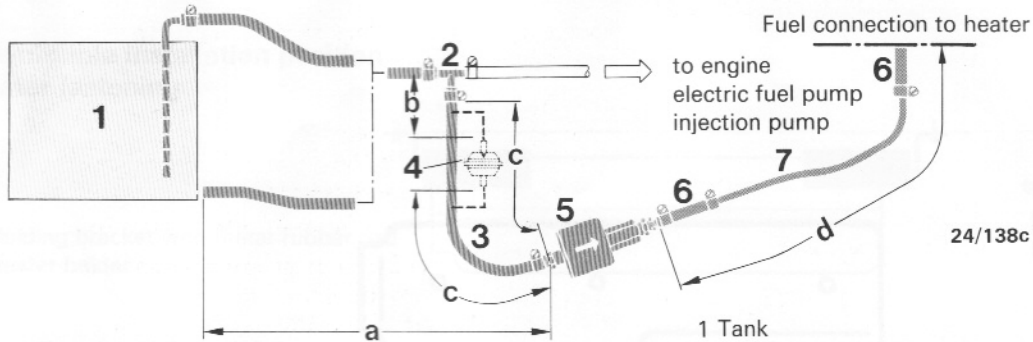

- 1 Tank
- 2 Fuel branch
- 3 Fuel tube, internal dia. 5 mm
- 4 Fuel prefilter (vertical, up to 30° downward if fuel line is tapped)  
Cat. No. 25 1226 89 00 37, only necessary if fuel is contaminated
- 5 Fuel metering pump (15° to vertical, inclined upward)
- 6 Fuel tube, internal dia. 3.5 mm
- 7 Fuel pipe, plastic, internal dia. 1.5 mm
- 8 Tank connection, internal dia. 2 mm
- 9 Tube or plastic pipe (max. internal dia. 5 mm)
- 10 Fuel pipe, plastic, internal dia. 2 mm

Dimension a = max. 750 mm with petrol  
max. 2000 mm with diesel oil

Dimension b = 50 mm

Dimension c = max. 300 mm

Dimension d = max. 4 m with petrol  
max. 6 m with diesel oil

Fuel pipe (7) and connections must touch at every joint.

### 2. Fuel intake separately from fuel tank or from separate tank (usually on trucks, construction machinery and agricultural machinery)

- A = intake from above
- B = lateral intake at tank
- C = lateral intake at tank or beneath it, and metering pump below lowest fuel level

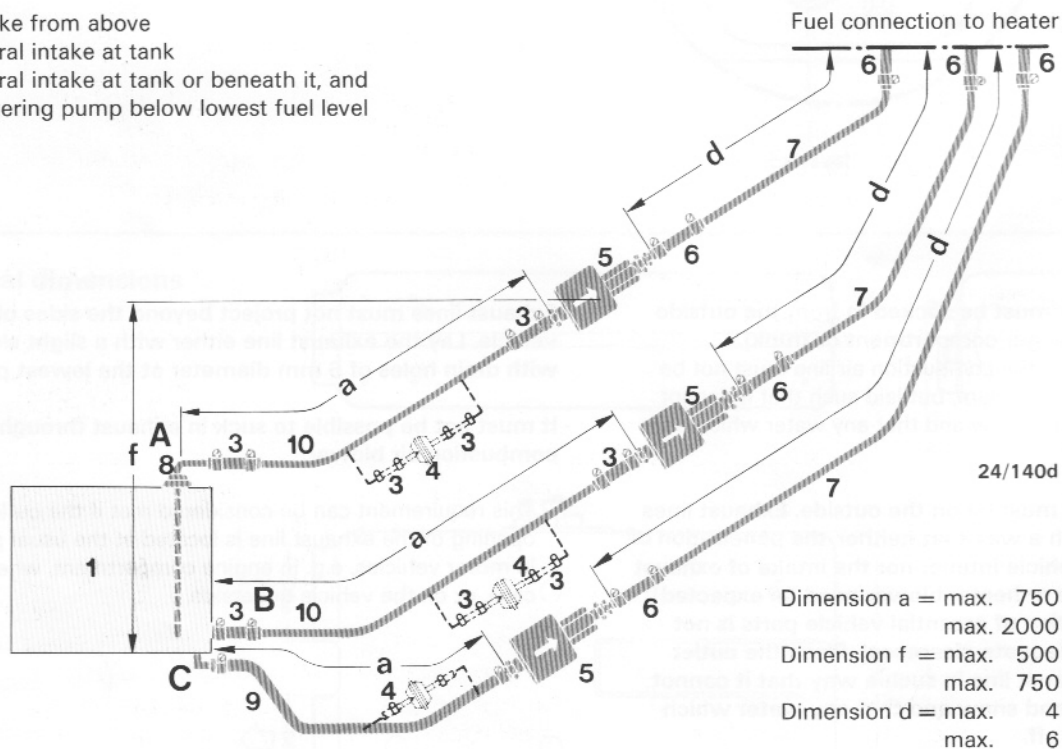

Dimension a = max. 750 mm with petrol  
max. 2000 mm with diesel oil

Dimension f = max. 500 mm with petrol  
max. 750 mm with diesel oil

Dimension d = max. 4 m with petrol  
max. 6 m with diesel oil

With connection types A and B, the intake line – A includes tank connection (8) – including all connection points must have an internal diameter of 2 mm; for this reason, fuel pipe (10) and connections must touch at every joint.

The fuel pipe (7) and the connections of the fuel supply line must as a general principle touch at every joint.

### 3. Permissible suction and pressure heads for installations as per 1. and 2.: permissible positioning of metering pump

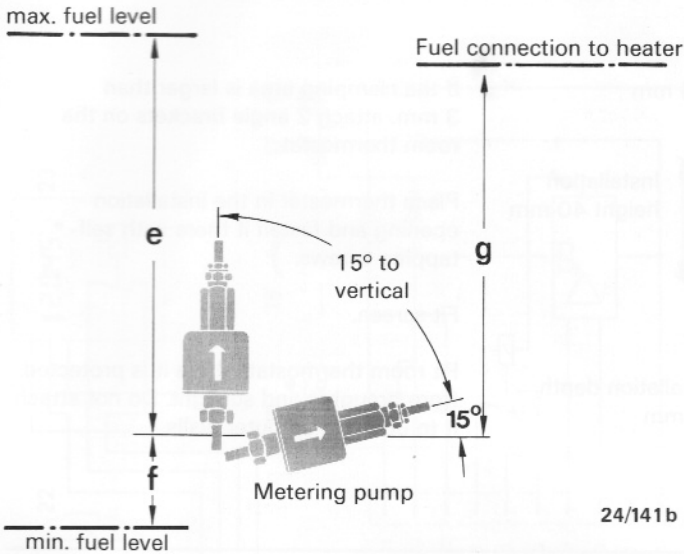

Supply pressure from tank to metering pump  
 $e = \text{max. } 3000 \text{ mm}$

Suction head:

with tank at zero pressure:

$f = \text{max. } 500 \text{ mm with petrol}$

$\text{max. } 750 \text{ mm with diesel oil}$

Check whether tank ventilation is working properly

intake from tank where underpressure occurs in operation (valve 0.03 bars in tank cap):

$f = \text{max. } 150 \text{ mm with petrol}$

$\text{max. } 400 \text{ mm with diesel oil}$

Pressure head, metering pump to heater:

$g = \text{max. } 2000 \text{ mm}$

Fuel line, metering pump to heater, should not have a slope if at all possible.

### 4. Important!

Sections 45 and 46 of the West German road traffic regulations (StVZO) also apply, with due alternation of details, for the fuel lines and additional tanks of heaters.

Protect fuel line, filter and metering pump from overheating; do not install near silencers and exhaust pipes. Temperatures above 30°C lead to gas bubbles and problems with petrol.

Cut fuel tubes and pipes to length only with a sharp knife. Cuts may not be indented, and must be burr-free.

When laying fuel line, fuel filter and fuel metering pump near the rear axle, allow for the spring deflection of the latter.

For connection of the fuel branches, always use rubber tubing, never plastic pipe.

Connect up fuel pipes with a fuel tube. Fit the fuel pipe flush.

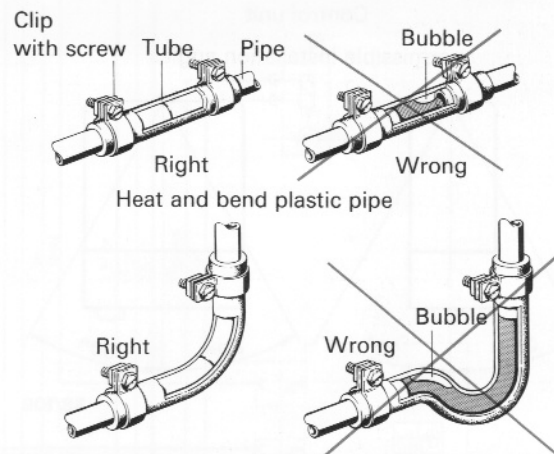
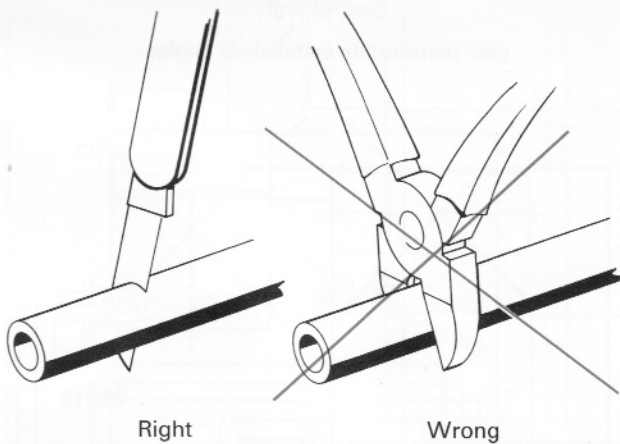

### Fuel for D 2 L at low temperatures

The heater can take without problem the same fuel you use in your tank.

The refineries automatically adapt their fuels to normal winter temperatures (winter diesel). Difficulties can therefore only arise at extremely low temperatures (as in the engine – see the vehicle's instruction manual).

If the heater is fuelled from a separate tank, the following rules must be observed: at temperatures above 0°C, any type of diesel fuel can be used. If there is no special diesel fuel available for low temperatures, mix in petroleum or petrol according to the following table.

Temperature	Winter diesel fuel	Additive
0°C to -15°C	100 %	–
-15°C to -25°C	50 %	50 % petroleum or petrol
-25°C to -40°C	–	100 % petroleum*

\*or special cold weather diesel fuels

The fuel line and the fuel pump must be filled with new fuel by operation for 15 minutes.

### Fuel for special cases

In special cases, the heaters can also be operated with extra-light fuel oil (above 0°C) or petroleum. If in doubt, please consult the manufacturer.

## Room thermostat

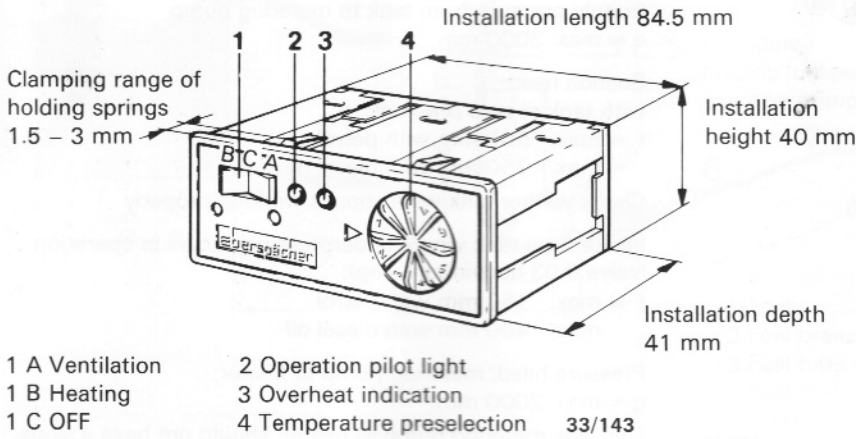

If the clamping area is larger than 3 mm, attach 2 angle brackets on the room thermostat.

Place thermostat in the installation opening and fasten it there with self-tapping screws.

Fit screen.

Fit room thermostat where it is protected from draughts and sunlight. Do not attach it to uninsulated outer walls.

## Electrics:

Arrange electric cables, switches and control units in such a way that their correct functioning cannot be impaired under normal operating circumstances.

Fit control unit so that it is protected from splash water (from both its own vehicle and the preceding one). Outside installation is therefore not permissible. The unit is best arranged in the vehicle interior, with the plugs pointing downward.

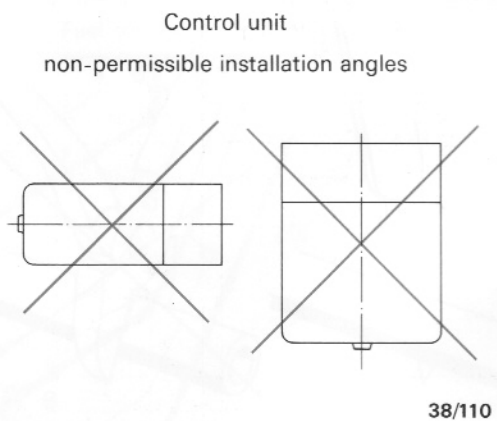
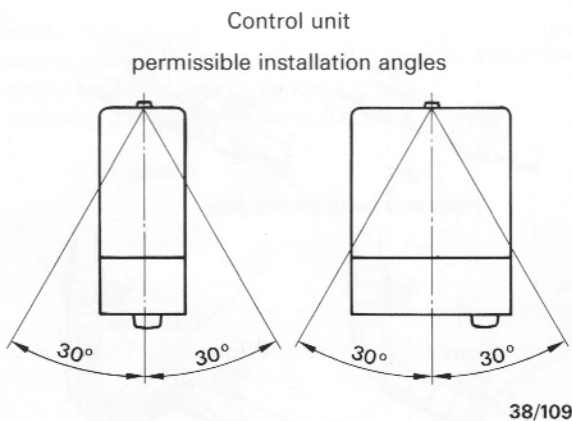

The following cable cross-sections must be observed between battery and heater, in order that the maximum permissible voltage losses in the cables (0.5 V at 12 V rated voltage and 1 V at 24 V rated voltage) are not exceeded.

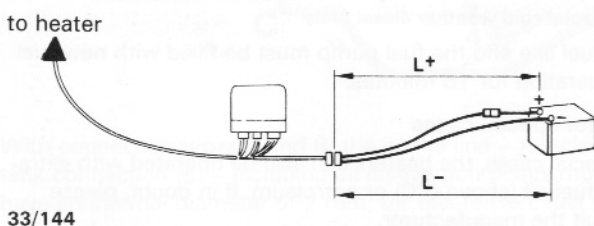

If the positive cable is to be connected to the fuse box (e.g. terminal 30), the vehicle's cable too from the battery to the fuse box must be included in the calculation of the total line length, and if necessary redimensioned.

Smear plug and earth connections outside the vehicle interior with contact protection grease.

$L^+ + L^- < 3 \text{ m} \rightarrow$  cross-section  $4 \text{ mm}^2$   
 $L^+ + L^- 3 \text{ to } 6 \text{ m} \rightarrow$  cross-section  $6 \text{ mm}^2$

## Wiring diagram

B 2 L - 12 V - 20 1667 05 00 00 (basic heater 20 1661 01)

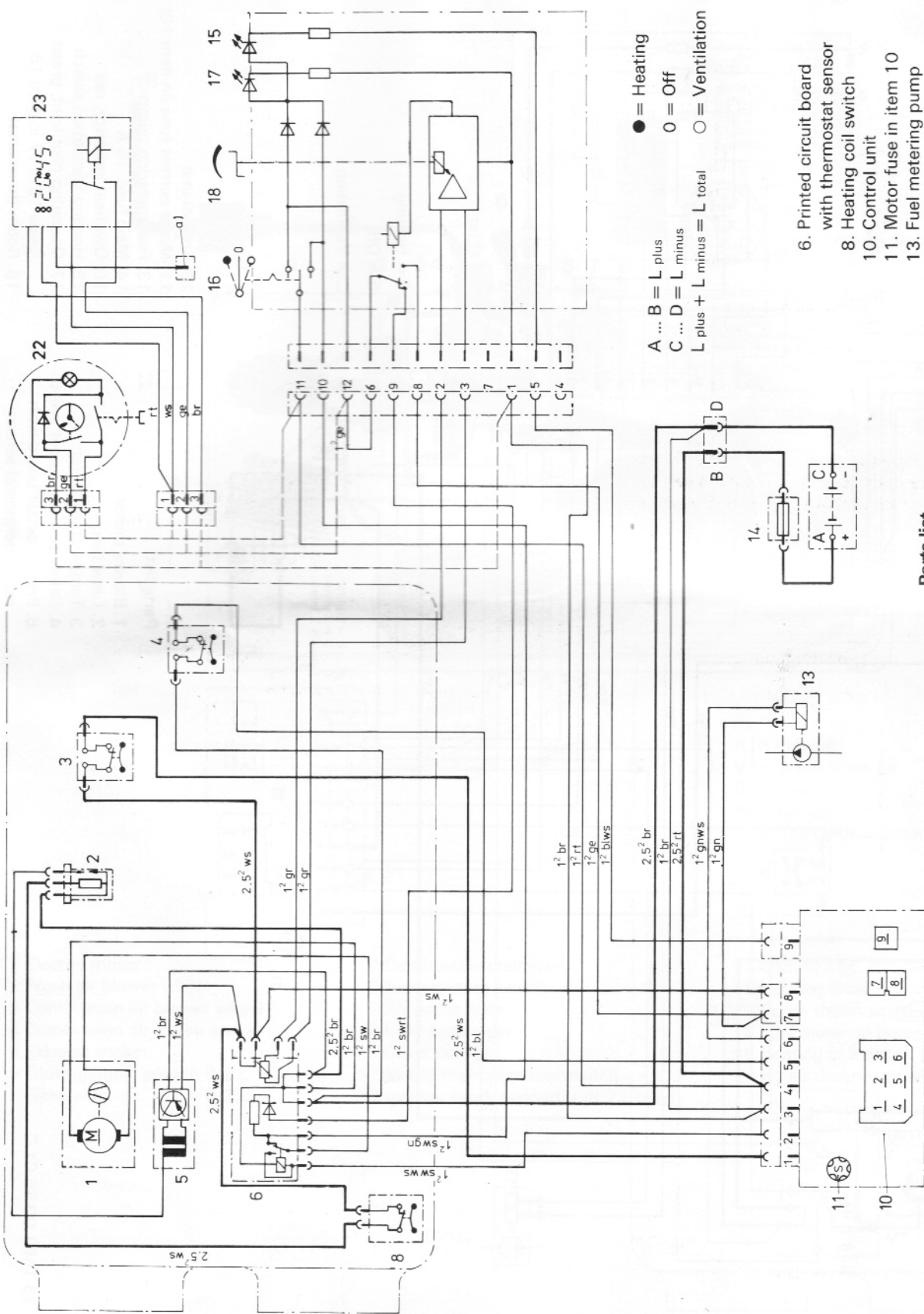

● = Heating  
 ○ = Off  
 ○ = Ventilation

A ... B = L plus  
 C ... D = L minus  
 L plus + L minus = L total

### Parts list

1. Blower motor
2. Glow ignition plug
3. Temperature switch
4. Safety thermal cutout switch
5. Ignition spark generator
6. Printed circuit board with thermostat sensor
8. Heating coil switch
10. Control unit
11. Motor fuse in item 10
13. Fuel metering pump
14. Main fuse
15. Overheat indicator, red
16. Heating/ventilation switch
17. Operating pilot light, green (items 15 - 17 in item 18)
18. Room thermostat

20 1661 00 96 01 D

# Wiring diagram

D 2 L - 12 V - 25 1625 05 00 00 (basic heater 25 1597 01)

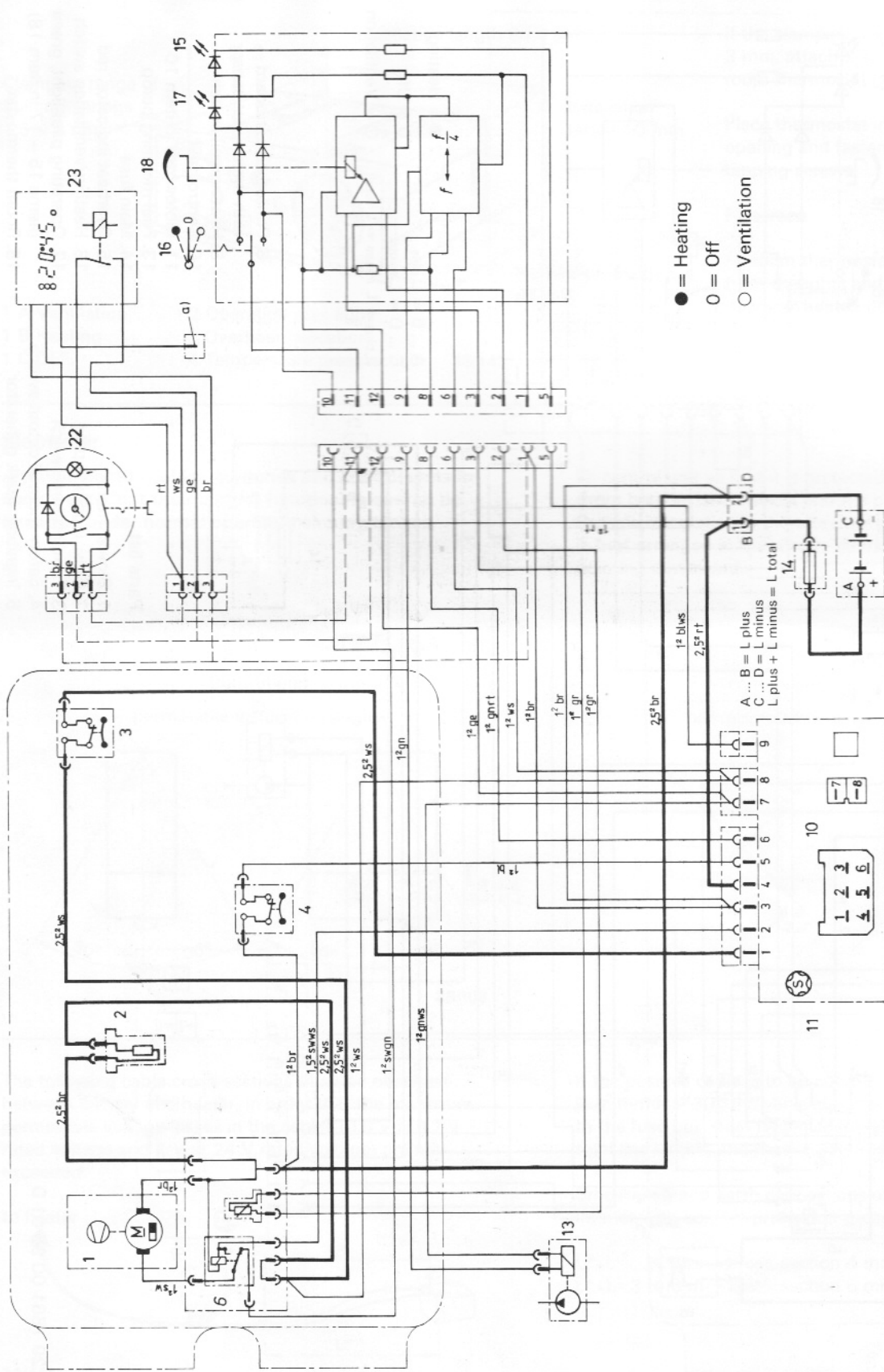

- = Heating
- 0 = Off
- = Ventilation

- 10. Control unit
- 11. Motor current fuse (in item 10)
- 13. Fuel metering pump
- 14. Main fuse, 16 A
- 15. Overheat indicator, red
- 16. Heating/ventilation switch
- 17. Operating pilot light, green items 15 - 17 in item 18
- 18. Room thermostat

### Parts list

- 1. Blower motor
- 2. Glow plug
- 3. Temperature switch
- 4. Safety thermal cutout switch
- 6. Printed circuit board with room thermostat sensor

25 1597 00 96 01 C

## Description of operation

Procedure after switching on/normal start

Switch-on:	Green pilot light on Room thermostat "On"
After max. 3 seconds:	Blower "On" at full speed in D 2 L: heating coil of glow plug "On" in B 2 L: heating coil and high voltage ignition of glow plug "On"
After approx. 30 seconds:	Fuel supply "On"
After approx. 90 seconds: (if heat exchanger is hot)	Temperature switch turns off glow plug/glow ignition plug

The heater now operates at full capacity, and the air heated in the heat exchanger passes through the outlet into the area to be heated.

Once the temperature set at the room thermostat is reached, the control mechanism starts to work:

**B 2 L** The fuel pump is switched off. The residual heat in the heater passes into the area to be heated until the normal delay in shut-off is over (approx. 3 minutes), at full blower speed and then at reduced blower speed.

Once the room temperature has dropped below that set at the thermostat, the thermostat switches the fuel supply back on and the heater is restarted.

A built-in heating coil switch ensures that the coil remains switched off in normal control operation if the ignition sparks are sufficient to form a flame.

**D 2 L:** The fuel quantity is reduced to approx. 25 %. This means that the heating capacity also drops to approx. 25 % (600 W). Once the room temperature has dropped below that set at the thermostat, the room thermostat switches the fuel quantity and thus the heating capacity back up to 100 %.

### Switch off:

Switching off results in the green pilot light going out. The blower shut-off is delayed so that it can cool down. The temperature switch ends it automatically.

## Controls and safety equipment

The flame is monitored by the temperature switch. This switch acts on the safety switch in the control unit, which shuts down the heater in the event of a malfunction.

a) Once a stable flame has been obtained, the temperature switch switches off the glow plug. In addition, it automatically stops the blower after switch-off once the heater has cooled off.

b) If the heater fails to ignite, it switches off automatically not more than 3 minutes after the fuel supply has started.

If a defective blower motor has caused the shutdown, the motor current fuse built into the control unit may have blown. Check the fuse and replace it if necessary. The heater can be switched back on by briefly switching the heater off and back on again. If the motor current fuse keeps blowing, a fault in the blower must be remedied.

c) If the flame goes out spontaneously during operation, the heater switches off automatically after a maximum of 4 minutes. Restart by switching off and on again.

d) The safety thermal cutout switch (attached to the heat exchanger) in conjunction with the electronic control unit switches off the fuel supply when the maximum permissible temperature of the heating air is exceeded, for instance due to clogging of the hot air ducts. At the same time, a red pilot light in the room thermostat flashes to indicate an overheat.

Once the cause of overheat has been eliminated, the heater can be put back into operation by switching it off and back on again. The red pilot light goes out.

e) Undervoltage/overvoltage safety device

An undervoltage/overvoltage safety device built into the control unit switches the heater off when the voltage at the control unit drops below 10.5 V or exceeds 15 V.